

---

# Automotive Suspension Systems

Course No: M02-038

Credit: 2 PDH

---

Robert P. Tata, P.E.

---



Continuing Education and Development, Inc.  
9 Greyridge Farm Court  
Stony Point, NY 10980

P: (877) 322-5800

F: (877) 322-4774

[info@cedengineering.com](mailto:info@cedengineering.com)

---

# **Automotive Suspension Systems**

**Copyright 2012**

**Robert Tata, B.S.M.E., P.E.**

**All rights reserved**

<b><u>Subject</u></b>	<b><u>Page</u></b>
Introduction	3
Types of Suspension Components	4
Suspension System Terms	5
Beam Axle Suspensions	6
Dual Beam Suspensions	7
Figure 1	8
Figure 2	9
Figure 3	10
Figure 4	11
Figure 5	12
Double Wishbone Suspension	13
Figure 6	14
Short/Long Arm Suspension	15
Figure 7	16
MacPherson Strut Suspension	17
Figure 8	18
Suspension Comparison	19

## Introduction

The suspension system of a vehicle refers to the group of mechanical components that connect the wheels to the frame or body. A great deal of engineering effort has gone into the design of suspension systems because of an unending effort to improve vehicle ride and handling along with passenger safety and comfort. In the horse and buggy days, the suspension system consisted merely of a beam (axle) that extended across the width of the vehicle. In the front, the wheels were mounted to the axle ends and the axle was rotated at the center to provide steering. The early automobiles used the one-piece axle design but instead of being rotated at the center, it was fix-mounted to the vehicle through springs to provide the cushioning of shock loads from road inaccuracies. The wheels were rotationally-mounted at the axle ends to provide steering. The first springs consisted of thin layers of narrow pieces of strip steel stacked together in an elliptical shape and were called leaf springs. In later installations, leaf springs were replaced by coil springs. In front-engine rear-drive vehicles, the front beam axle was replaced by independently mounted steerable wheels. The wheels were supported by short upper and lower hinged arms holding them perpendicular to the road as did the previous axle beam designs. A coil spring was used to support either the upper or the lower arm to provide dampening. Shock absorbers began to be used to dampen shock loads and also to provide resistance to spring oscillations. Later it was learned by shortening the upper arm; wheel tilt (camber) could be controlled to prevent edge loading tires while cornering. The power transmitting drive axle in the rear served as the beam-type suspension with dampening provided by either leaf or coil springs as well as shock absorbers. When front-engine front-drive passenger cars were introduced, the upper arm was rotated up and replaced by a member called a "strut" which contained the concentrically mounted spring and shock. This arrangement provided additional space for transverse mounted engine/transmission modules and the front drive shaft. This same type of suspension was also used in the rear of many cars. Trucks continue to be front-engine, rear-drive vehicles many of which are using beam-type axle suspension systems in both the front and rear. This course will study the design and application of five currently used suspension systems.

## **Types of Suspension Components**

There are three basic types of suspension components: linkages, springs, and shock absorbers. The linkages are the bars and brackets that support the wheels, springs and shock absorbers. Springs cushion the vehicle by dampening shock loads from bumps and holes in the road. Shock absorbers use hydraulic pistons and cylinders to cushion also the vehicle from shock loads. They also serve to dampen spring oscillations, thus bring the vehicle back to a neutral position soon after being shock loaded by a road obstruction.

**Links:** There are a number of various shaped links that are used for the different types of suspension systems. They vary from straight bars to forged, cast or stamped metal shapes that best fit to support the springs, shocks and wheels onto vehicle frames or body structures. The simplest linkage is a straight bar that connects one wheel to the other on the opposite side of the vehicle. Others can be intricately shaped to connect springs, shock absorbers and wheels to vehicles as explained later.

**Springs:** There are three different spring types that are used in suspension systems: coil, leaf and torsion bar. Coil springs are merely wound torsion bars. They are commonly used because they are compact, easily mounted and have excellent endurance life properties. Leaf springs are long thin members that are loaded in bending. They are used as an assembly being comprised of several layers of thin metal to obtain the correct spring rate. Leaf springs serve as both the damping member and the linkage. Torsion bars rely on the twist of a long bar to provide a spring rate to dampen car shock loading. Torsion bars mount across the bottom portion of a vehicle and are more difficult to package than others.

**Shock Absorbers:** Shock absorbers use a piston and cylinder along with adjustable valves to control the flow of hydraulic fluid to set the damping force in both the retract (jounce) and extend (rebound) positions. Shock absorbers are set to retract under a lower force than to extend. This action absorbs road bump forces and dampens spring oscillations resulting in better vehicle ride and control.

## Suspension System Terms

- **Camber**: Looking directly at the front of the vehicle, camber refers to the tilt in (+) or out (-) of the bottom half of the tire.
- **Caster**: Looking directly at the side of the vehicle, caster refers to the tilt rearward (+) of the bottom half of the tire.
- **Toe**: Looking directly at the top of the vehicle, toe refers to the slant in (+) or out (-) of the front half of the tire.
- **Jounce**: Jounce refers to the bounce or vertical movement of the vehicle suspension upward when it contacts a bump in the road.
- **Rebound**: Rebound refers to the movement of the vehicle suspension in the opposite direction of jounce.
- **Shimmy**: Shimmy is an uncontrollable oscillation of the steering system experienced by two opposing wheels.
- **Knuckle**: The knuckle is the suspension component that incorporates the spindle or hub that the wheel bearings and wheels mount on.
- **King Pin**: The king pin is the vertical component in the knuckle that the wheels turn on when the vehicle is steered.
- **Spindle**: The spindle is the long tapered bar-shaped piece that is fitted to the knuckle on which the wheel bearings and wheels are mounted.
- **Hub**: The hub is the hollow part of the knuckle that replaces the spindle in mounting the bearings that support the wheel.
- **Ball Joint**: A ball joint is a fastener or connector that allows movement in all directions.
- **Tie Rod**: A tie rod is a component that firmly connects one wheel of a vehicle to the wheel on the opposite end to provide steering.
- **Track Bar**: A track bar is a rod that connects a suspension beam to the frame to give lateral support.
- **Unsprung Weight**: Unsprung weight is the total weight of all components in a vehicle that are not dampened by the springs and shocks like the wheels and other closely associated equipment.
- **Scrub**: Scrub is the lateral movement of a tire against the pavement due to suspension system camber changes during jounce and rebound.

## Types of Suspension Systems

**Beam Axle:** Initially, the front axle of rear-drive automotive vehicles was of a solid beam design. It consisted solely of a fixed continuous member extending across the entire front end of the vehicle connecting the two steerable wheels. This is referred to as a “dependent” suspension system as the two wheels are mechanically linked together as opposed to an “independent” suspension system where the two wheels are not directly linked together. The original Model T passenger cars were rear-drive and had a dependent front suspension system whereby a solid beam axle extended across the entire width of the vehicle connecting the two wheels. The axle was of forged I-beam steel construction and had ends machined to allow the assembly of vertically mounted kingpins enabling the wheels to rotate to provide for vehicle steering. To dampen the ride, a transverse mounted semi-elliptical inverted leaf spring was installed between the axle and the car body. The two downward curved ends of the leaf spring were fastened to each end of the axle while the higher center section was fastened in two closely spaced locations directly to the car frame. (See Figure 1.)

Solid beam axles can also be used for drive wheels where the drive axle assembly itself serves as the solid beam member connecting the two drive wheels of a vehicle such as that used on the Model T. Drive axles contain a number of mechanical components that deliver power from the engine, through the drive shaft, to the drive axle which diverts it 90 degrees to the wheels of automotive vehicles. Figure 2 has sketches of drive axles acting as solid beam suspension members. The upper sketch has a drive axle mounted on rear trailing suspension arms and dampened by coil springs and shock absorbers. The small bar shown is called the “track bar” and connects to the vehicle frame to serve as lateral support for the drive axle. The lower sketch of Figure 2 depicts a drive axle located in the front of a four-wheel-drive vehicle. The linkage and “tie rod” shown provide for vehicle steering. Figure 3 has a sketch of a drive axle supported by leaf springs. The drive axle center section is an interesting design having three sets of bevel gears to deliver engine power 90 degrees to the two drive wheels. Figure 4 has a section drawing of the center section of a typical drive axle. The first gearset takes power from the vehicle drive shaft and delivers it 90 degrees to a

component called the carrier. The carrier houses the “differential”. The differential is an ingenious device that delivers power to each of the two drive wheels regardless of the rotational speed of each such as when a vehicle is traveling around a corner. Drive axles were traditionally used for automotive vehicle rear wheels and for the front of four-wheel-drive automotive vehicles. More recently, many automotive vehicles have gone to front-wheel-drive where the transmission and drive axle are combined and called the “transaxle”.

The advantages of solid beam axles are that they are simple and strong. Also, wheel camber is closely controlled with the wheel held virtually perpendicular to the road during vehicle vertical movement. This is of particular advantage for trucks carrying heavy loads in keeping the wheels 90 degrees to the pavement. A disadvantage of solid beam axles is that there is no camber adjustment made during heavy cornering to keep the wheels off their edges and firmly in contact with the pavement like another form of a suspension system (discussed later). Another disadvantage is, since both wheels are connected together, a vehicle with one wheel encountering a bump or depression on the road sends a shock wave across the entire rear (or front) of the vehicle leading to passenger discomfort and possible “shimmy”. Also, solid beam axles add high unsprung weight to a vehicle leading to a harsher vehicle ride and passenger discomfort.

**Dual-Beam Suspension:** Dual-beam front suspension is popular with one U.S. auto manufacturer for light trucks. (See Figure 5). Dual beam suspensions are considered “independent” suspension systems as the two wheels are not directly connected as they are on the solid beam suspension discussed above. The major advantage of dual-beam suspension is that front shock loads from pavement anomalies are isolated to the side where they are encountered. This is opposed to one-piece front beam suspensions where shock loads encountered on one wheel are transported all the way across the vehicle causing excessive body shock loading and passenger discomfort. The disadvantage of dual-beam front suspensions is that the wheel camber changes with vehicle vertical movement causing tire edge wear and wheel scrubbing. The dual suspension arms of the dual beam system used by the U.S. automaker for light trucks overlap each other and are as long as the design allows minimizing the above mentioned disadvantages.



Figure 1

Solid Beam Suspensions

Ford Model T  
Front Suspension  
Schematic

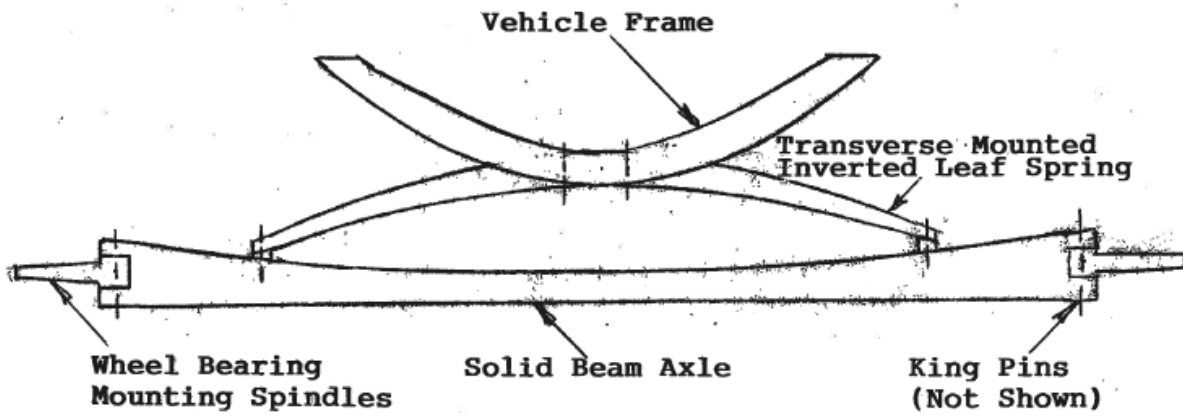
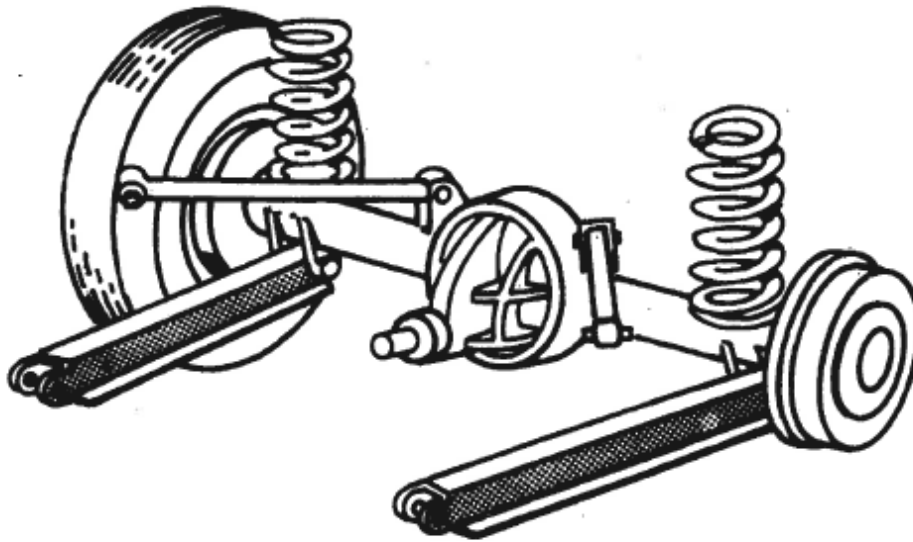
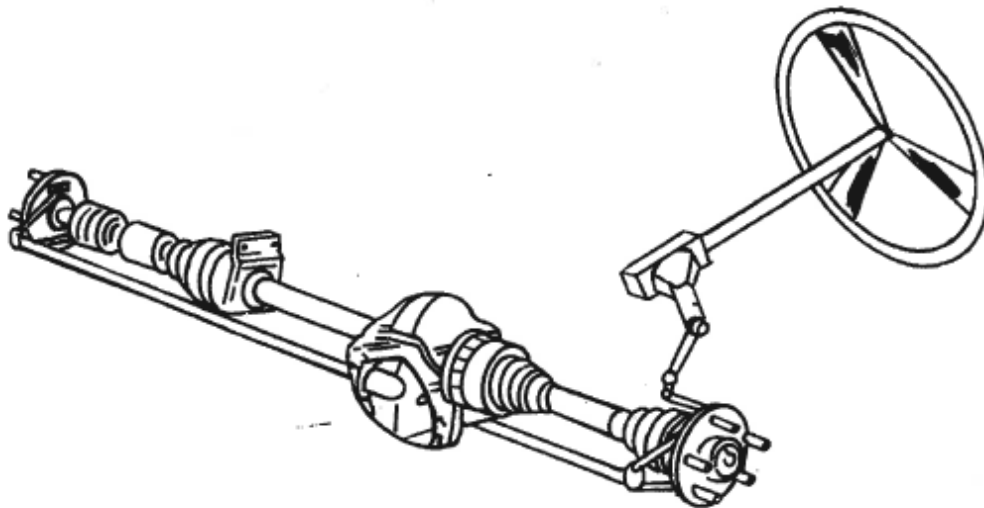

Figure 2

Drive Axle  
as  
Solid Beam Suspension Member



Rear Drive Axle Suspension System



Front Drive Axle With Steering

Figure 3

Drive Axle Supported By Leaf Springs

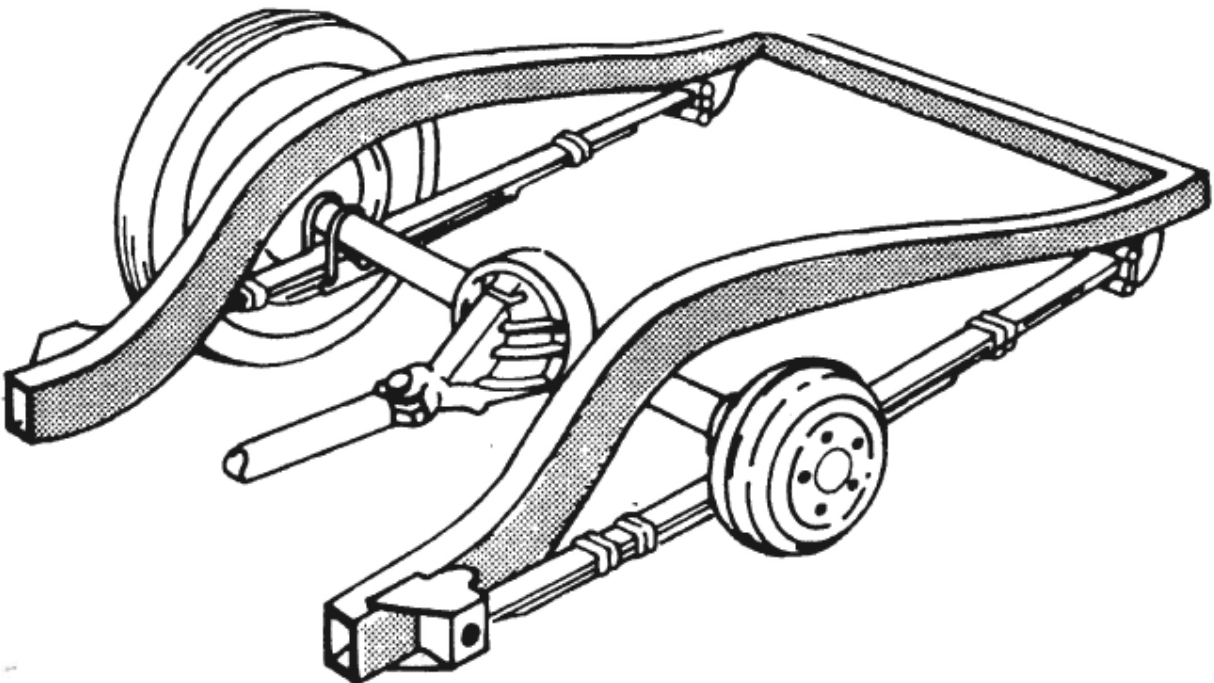
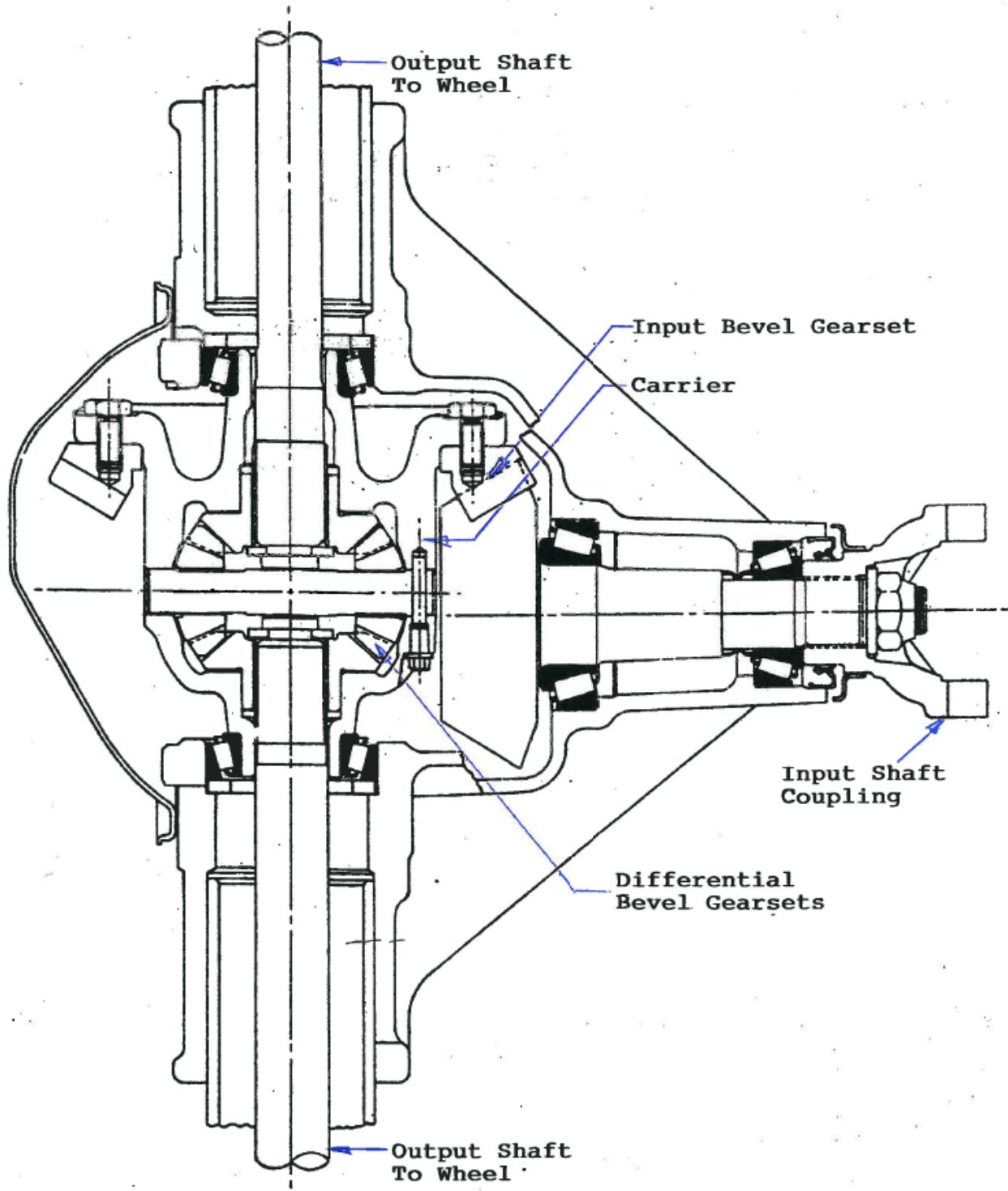

Figure 4

Drive Axle Center Section



**Figure 5**  
**Dual Beam Suspension**

**Light Truck**  
**Front Suspension**  
**Schematic**

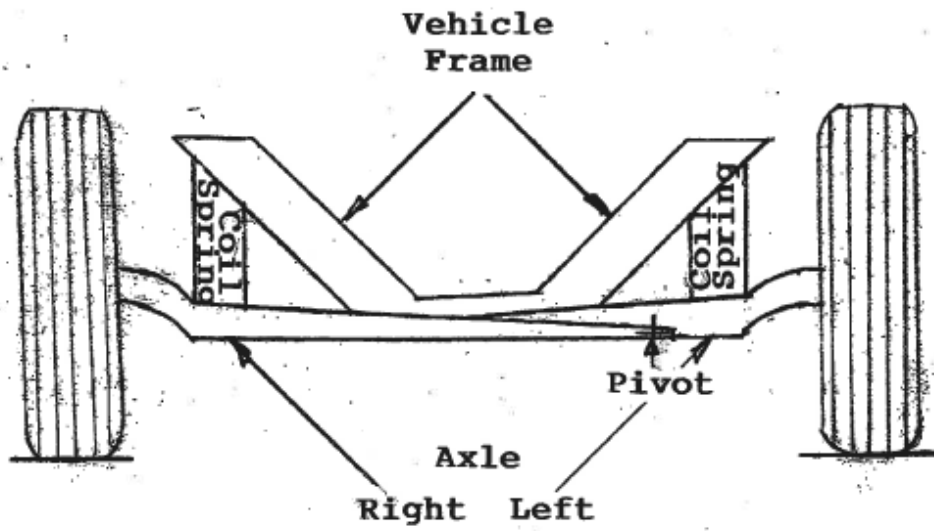

**Double Wishbone Suspension:** The double wishbone suspension was first used in the 1930's in Europe and then in 1935 in Detroit. Many vehicles used it until front wheel drive cars came into being starting in the 1970's when a form of the double wishbone suspension called the MacPherson strut came to be heavily used (as discussed later). The double wishbone is classified as an independent suspension system that has been used to replace the beam type dependent suspension systems previously discussed (see Figure 6). The double wishbone suspension system consists of two equal-sized short wishbone shaped members (arms) positioned one over the other. The closed ends of the two wishbone arms are hinge mounted to the top and bottom of the vehicle knuckle to provide vehicle steering. The vehicle knuckle supports the spindle or hub to which the wheel is mounted. The two open ends of each wishbone member are hinge-mounted to the vehicle frame. In the event that the double wishbone suspension is used for a drive-wheel application, a coil spring is seated on the central portion of the upper arm as shown on Figure 6 and extends upward where it is supported by a body member. In this case, the upper arm supports most of the vertical load and there is space for the vehicle drive shaft below. When the double wishbone suspension is used on a non-drive wheel application, the coil spring is seated in the central portion of the lower arm and again extends upward to a body support member, with the lower arm supporting most of the vehicle load.

The wishbone suspension is lighter than the beam type suspension system but is more costly, as the two wishbone links are more intricately shaped and have six attachment points as opposed to just two for solid beam type suspension systems. Both systems support the wheels in a perpendicular pattern to the road giving them an advantage over some other suspension systems which, as previously explained, change wheel camber throughout suspension travel creating tire edge wear and wheel scrubbing on the road surface although, on some vehicles, as will be explained later, closely controlled camber change with suspension travel can be an advantage. Other parameters can be controlled throughout suspension travel with double wishbone suspension systems such as camber angle, caster angle, and toe angle.

Figure 6

Double Wishbone  
Suspension Schematic

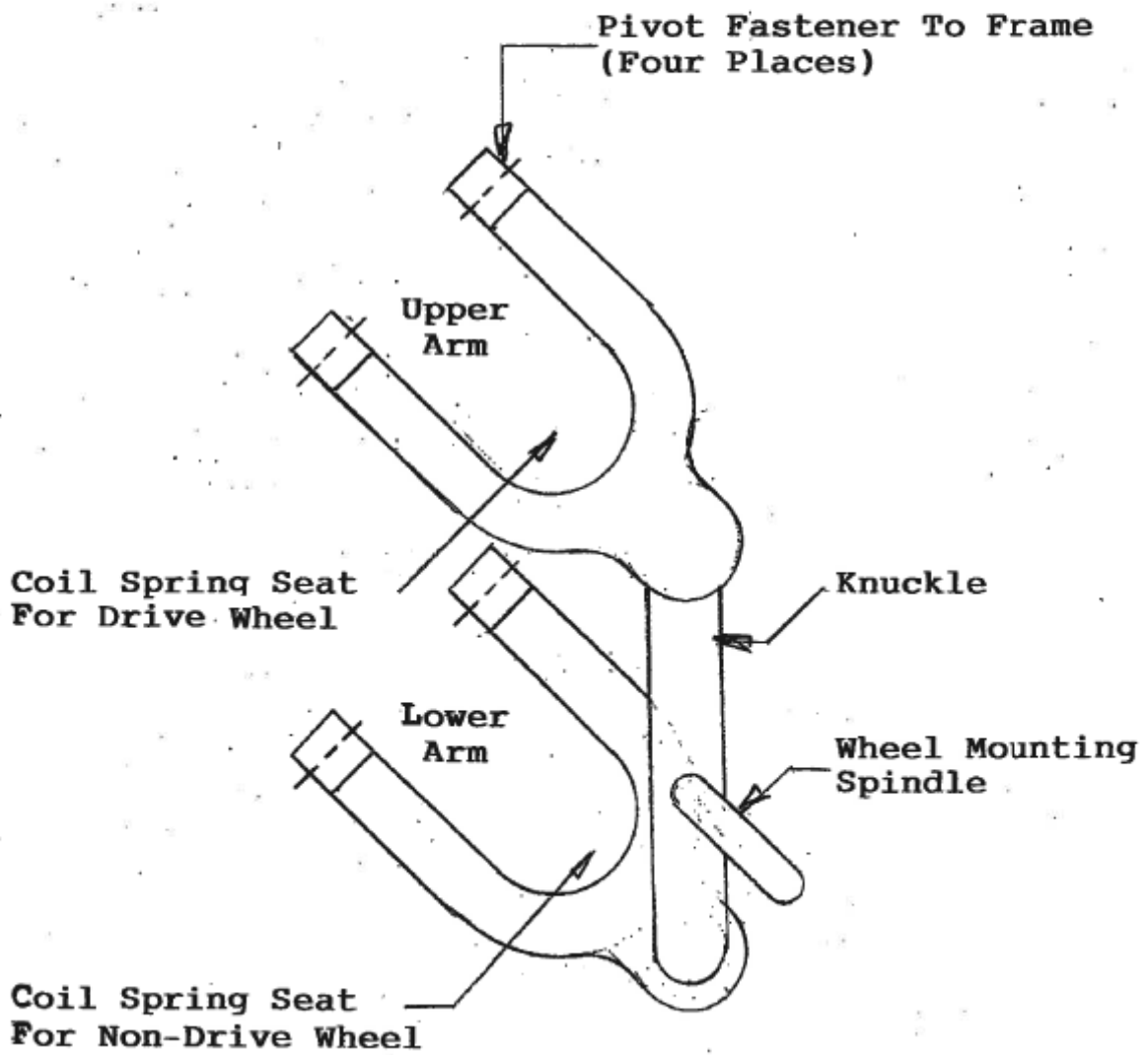

**Short/Long Arm Suspension:** The short/long arm suspension is a modification of the double wishbone suspension that can be used on both the front and rear wheels of automotive vehicles. In the double wishbone suspension the two arms are of equal length. In a short/long arm (SLA) suspension, the two arms are of unequal length with the upper arm being shorter than the lower arm. (There are other versions of double wishbone suspensions with even different relative arm lengths.) The short/long arm suspension is considered to be an independent suspension since the two wheels are not directly connected as they are on the solid beam type. (See Figure 7).

The closed (outboard) end of the upper and lower wishbone members is attached to the knuckle which contains the spindle to which the wheel is mounted. Both arm to knuckle connections are made using a pivoting joint to allow for vehicle steering. The two inboard ends of both arms are connected to a vehicle structural member through rubberized joints which allow the arm to pivot accommodating wheel up and down movements.

This design helps to control camber and limit tire edge wear while cornering a vehicle. The length of the upper arm is made shorter so that, when cornering, with centrifugal force tending to roll the vehicle and putting tires on their edges, this suspension system acts to move the contact pattern back to the center of the tire for both wheels. This effect takes place all the way to full jounce making it an ideal suspension for performance vehicles. The coaxial spring and shock absorber can be mounted on the lower arm for non-drive wheel systems and on the upper arm for drive wheel installations. This design weighs and costs about the same as the popular Macpherson Strut suspension which will be discussed later. It takes up more useable space than the Macpherson strut suspension and; therefore, does not allow as much room for a transverse mounted engine and front drive shaft that is common to many of today's fuel efficient cars that use the Macpherson strut. It is best used for the wheels of a front inline mounted engine, rear drive vehicle.



**Figure 7**

**Short Long Arm (SLA)  
Suspension Schematic**

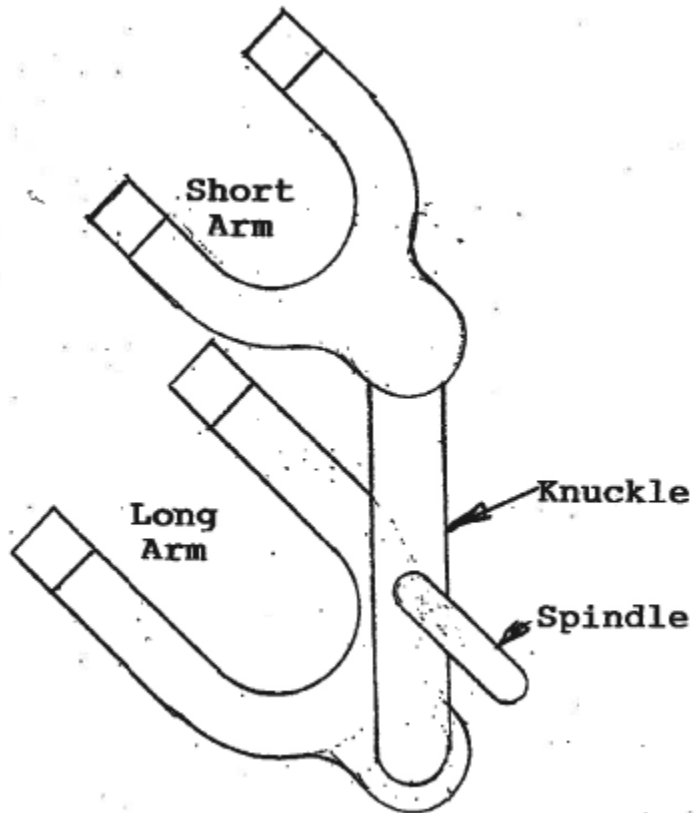

**MacPherson Strut Suspension:** The strut was invented by Earle S. Macpherson, an American automotive engineer in 1947. The Macpherson strut suspension is a lighter weight suspension system than a beam suspension and has about the same weight and cost as the short/long arm suspension discussed above. Like the short/long arm suspension, it is classified as an independent suspension. It came into popularity in the 1970's when light weight, front drive cars became the norm because of government regulations requiring more fuel efficient operation.

The MacPherson strut suspension is like the short/long suspension except that the upper arm is rotated 90<sup>0</sup> up and outboard to a near vertical position, and replaced with a long member as shown on Figure 8. This upper member, called the strut, contains a coaxial mounted spring and shock absorber with an anti-friction thrust bearing at the top. In a typical application, it is positively attached at the top to a body structure and also positively attached at the bottom to the knuckle. It is designed to support vertically applied suspension loads and rotates on the upper bearing with the wheel during vehicle steering. It helps to control camber during vehicle cornering like short/long arm suspension systems but not throughout full jounce because of the change in length and mounting angle of the strut compared to the SLA short upper arm. Rotating the upper arm assembly up and outboard creates space needed for the transverse mounted engine and drive shaft in the light weight, front drive vehicles that have become so popular. The design uses a similar lower wishbone shaped link to provide both lateral and longitudinal support for the wheel.

On some of the same vehicles, a strut is also used in the rear suspension system. It is similar to the front strut but does not have the anti-friction bearing at the top because of being on a non-steerable wheel.

**Figure 8**

**MacPherson Strut  
Suspension Schematic**

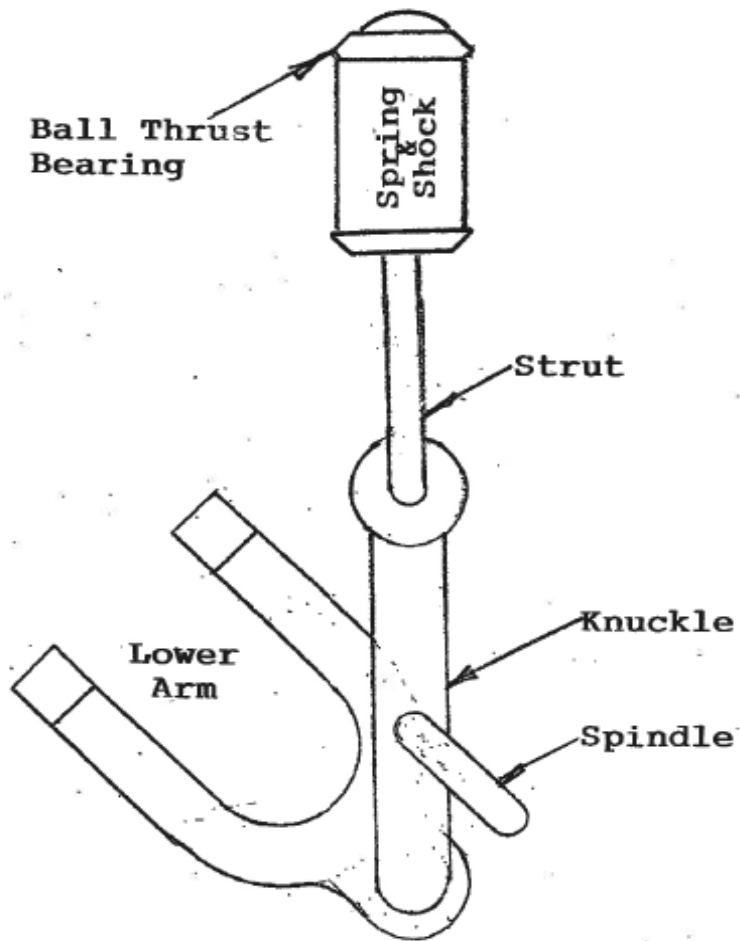

## **Suspension Comparison:**

- **Beam Axle**: This is a type of suspension that is a strong, sturdy and maintains good tire contact with the road under all load conditions. It is a “dependent” type meaning the wheels are mechanical connected such that when one hits an obstruction on the road, it is felt across the entire width of the vehicle. This suspension is good for trucks.
- **Dual Beam Axle**: This is a strong, sturdy suspension that does not maintain as good contact with the road as the beam axle suspension. It is an “independent” type of suspension meaning that the wheels are not mechanical connected such that when one hits an obstruction on the road, it is not felt across the entire width of the vehicle. It is used on light truck front.
- **Double Wishbone**: This is a lighter, more costly suspension than the beam type but adds more room for packaging other components. It is an independent type of suspension that keeps good tire contact with the road under full suspension travel. Camber, caster, and toe can be closely controlled. Good for passenger cars.
- **Short/Long Arm**: This type of suspension is similar to the double wishbone except that the upper arm is made shorter than the lower arm. This design feature maintains good tire contact with the road under all cornering conditions. It is good for performance vehicles.
- **MacPherson Strut**: This type of suspension is similar to the double wishbone except that the upper arm is rotated up and replaced with a long member called the “strut”. The strut incorporates the spring and shock in a concentric package and attaches to mounts high on the vehicle. This design adds more room for packaging front engine/transmission modules and adjoining drive shafts.